

## CM 20SB – Technical Specifications (rev2 01/05/01)

|                             |   |
|-----------------------------|---|
| <b>Description:</b>         | <ul style="list-style-type: none"> <li>• A compact, sub bass enclosure, with 150Hz low pass filter.</li> <li>• For optimum bass response use with EQ1520 controller.</li> </ul> |
| <b>Frequency Response:</b>  | <ul style="list-style-type: none"> <li>• 45Hz – 150Hz</li> </ul>  |
| <b>Components:</b>          | <ul style="list-style-type: none"> <li>• Sub Bass: 1 x 18" cone driver</li> </ul>   |
| <b>Power handling:</b>      | <ul style="list-style-type: none"> <li>• 1Kw</li> </ul>   |
| <b>Sensitivity (1):</b>     | <ul style="list-style-type: none"> <li>• 98dB</li> </ul>  |
| <b>Directivity:</b>         | <ul style="list-style-type: none"> <li>• Omni-directional</li> </ul>  |
| <b>Construction:</b>        | <ul style="list-style-type: none"> <li>• 18mm Birch plywood</li> </ul>  |
| <b>Finish:</b>              | <ul style="list-style-type: none"> <li>• Water based textured black paint (M-Spec and T-Spec)</li> <li>• Royal Blue carpet (R-Spec)</li> </ul>                                  |
| <b>Connections:</b>         | <ul style="list-style-type: none"> <li>• 2 x Neutrik NL4 connectors</li> <li>• 1+/- input 2+/- No connection</li> </ul>   |
| <b>Dimensions:</b>          | <ul style="list-style-type: none"> <li>• 505mm (W) x 780mm (H) x 500mm (D)</li> </ul>   |
| <b>Packaged Dimensions:</b> | <ul style="list-style-type: none"> <li>• 520mm (W) x 805mm (H) x 515mm(D)</li> </ul>  |
| <b>Impedance:</b>           | <ul style="list-style-type: none"> <li>• 8 ohms nominal</li> </ul>  |
| <b>Weight:</b>              | <ul style="list-style-type: none"> <li>• 49 Kg</li> </ul>   |

**Note:** (1) Sensitivity measured at 1 metre with 2.83V, using band limited pink noise.

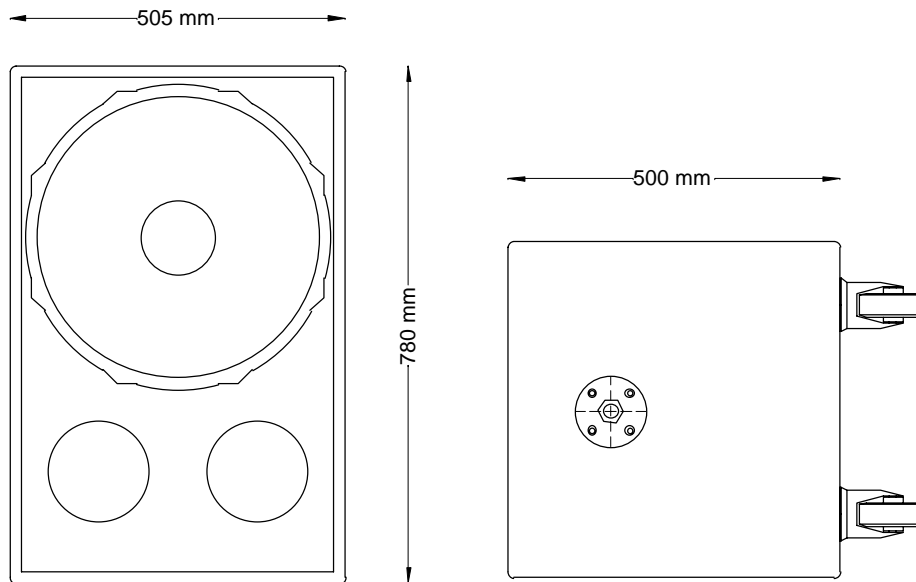

## CM 20SB Options

| Cabinet | Code    | Spec.  | Handles | Tophat | M20 plate | M20 Blank | Castors | Bracket | Inserts/Fly Points |
|---------|---------|--------|---------|--------|-----------|-----------|---------|---------|--------------------|
| CM 20SB | LS 2046 | R-Spec | 4 off   | No     | Yes (2)   | No        | Yes     | No      | No                 |
|         | LS 4046 | M-Spec | 4 off   | No     | No        | Yes (2)   | No      | No      | No                 |
|         | LS 6046 | T-Spec | 4 off   | No     | Yes (2)   | No        | Yes     | No      | No                 |