

## CS 1090 – Technical Specifications (rev2 01/05/01)

<b>Description:</b>	• A compact, fully horn loaded, passive, mid/top enclosure.
<b>Frequency Response:</b>	• 220Hz – 18KHz
<b>Components:</b>	• Mid: 10" cone driver • HF: 2" exit compression driver on CD horn
<b>Power handling:</b>	• 300w
<b>Sensitivity (1):</b>	• 103dB
<b>Directivity:</b>	• 90H x 40V
<b>Construction:</b>	• 15mm Birch plywood
<b>Finish:</b>	• Water based textured black paint (M-Spec and T-Spec) • Royal Blue carpet (R-Spec)
<b>Connections:</b>	• 2 x Neutrik NL4 connectors • 1+/1- thru 2+/2- Input
<b>Dimensions:</b>	• 430mm (W) x 629mm (H) x 400mm (D)
<b>Packaged Dimensions:</b>	• 445mm (W) x 655mm (H) x 415mm(D)
<b>Impedance:</b>	• 8 ohms nominal
<b>Weight:</b>	• 30 Kg
<b>Note:</b>	(1) Sensitivity measured at 1 metre with 2.83V, using band limited pink noise.

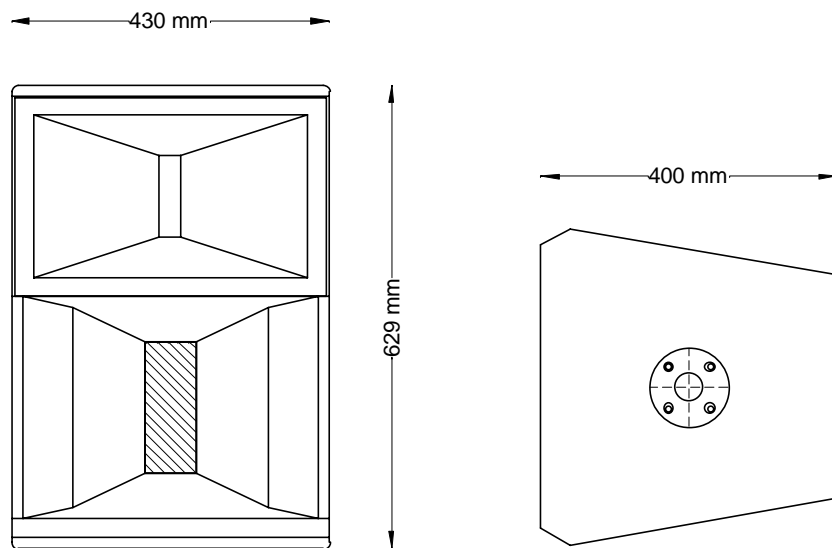

## CS 1090 Options

Cabinet	Code	Spec.	Handles	Tophat	M20 plate	M20 Blank	Castors	Bracket	Inserts/Fly Points
CS 1090	LS 2035	R-Spec	2 off	Yes	No	No	No	No	No
	LS 4035	M-Spec	2 off	Yes	No	No	No	No	5 off M10 inserts
	LS 6035	T-Spec	2 off	Yes	No	No	No	No	3 off Fly plates