

## CS I290B – Technical Specifications (rev: 4 10/06/05)

<b>Description:</b>	<ul style="list-style-type: none"> <li>• A compact, push/pull bass enclosure.</li> <li>• Requires 6<sup>th</sup> order EQ for optimum bass performance. (Refer to DSP settings.)</li> </ul>
<b>Frequency Response:</b>	<ul style="list-style-type: none"> <li>• 40Hz – 150Hz</li> </ul>
<b>Components:</b>	<ul style="list-style-type: none"> <li>• Bass: 2 x 15” cone driver</li> </ul>
<b>Power handling:</b>	<ul style="list-style-type: none"> <li>• 1Kw</li> </ul>
<b>Sensitivity (1):</b>	<ul style="list-style-type: none"> <li>• 101dB</li> </ul>
<b>Directivity:</b>	<ul style="list-style-type: none"> <li>• Omni-directional</li> </ul>
<b>Construction:</b>	<ul style="list-style-type: none"> <li>• 18mm Birch plywood</li> </ul>
<b>Finish:</b>	<ul style="list-style-type: none"> <li>• Dark Grey carpet</li> </ul>
<b>Connections:</b>	<ul style="list-style-type: none"> <li>• 2 x Neutrik NL4 connectors</li> <li>• 1+/1- Input 2+/2- linked</li> </ul>
<b>Dimensions:</b>	<ul style="list-style-type: none"> <li>• 505mm (W) x 780mm (H) x 600mm (D)</li> </ul>
<b>Packaged Dimensions:</b>	<ul style="list-style-type: none"> <li>• 520mm (W) x 805mm (H) x 615mm(D)</li> </ul>
<b>Impedance:</b>	<ul style="list-style-type: none"> <li>• 4 ohms nominal</li> </ul>
<b>Weight:</b>	<ul style="list-style-type: none"> <li>• 63 Kg</li> </ul>

**Note:** (1) Sensitivity measured at 1 metre with 2.83V, using band limited pink noise.

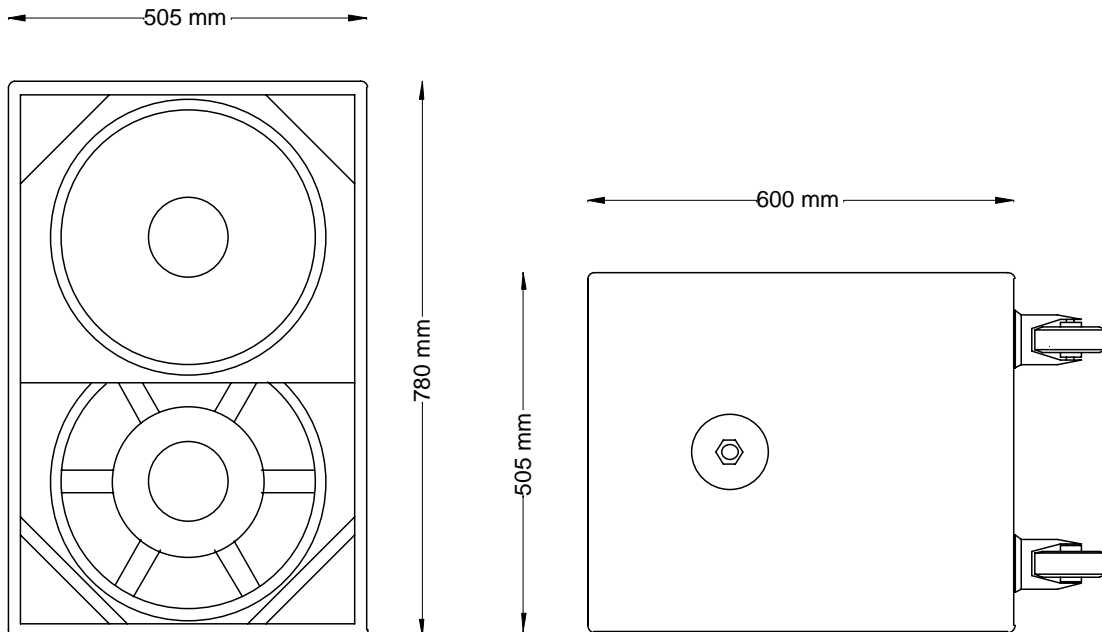

## CS I290B Options

Cabinet	Code	Handles	Tophat	M2o plate	M2o Blank	Castors	Bracket	Inserts/Fly Points
CS I290B	LS 2029	4 off	No	Yes	No	Yes	No	No