

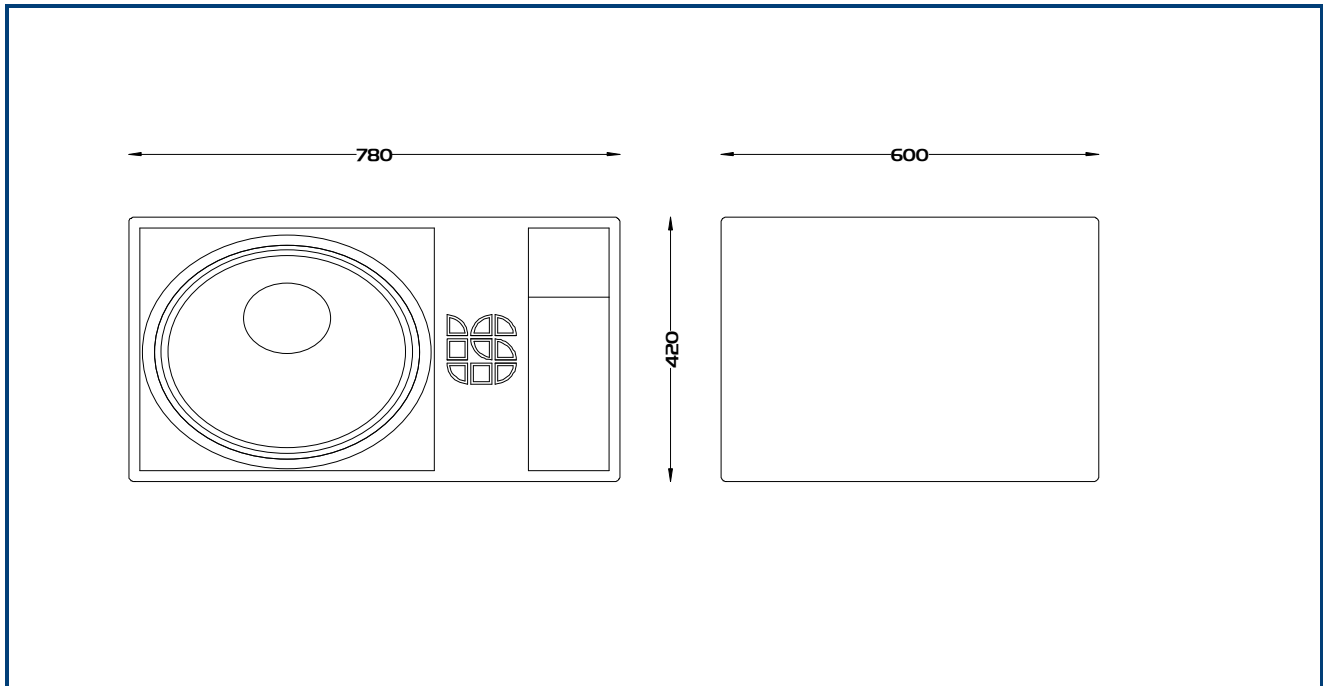

The SB1 is a high power sub bass cabinet. It utilises an 18" bass cone loaded into a vented back cavity, while the front of the driver is loaded into a manifold that helps to improve performance between 80-150Hz. The SB1 is designed to be used in the landscape mode and will only give optimum performance when used in this mode. The SB1 was designed to be used as part of an integrated system with the ML15 enclosures, but also has applications as a compact bin for installation. Its low profile gives flexibility when space is at a premium.



Frequency Response:	<ul style="list-style-type: none"> • 45Hz – 150Hz
Components:	<ul style="list-style-type: none"> • Bass: 18" cone driver • HF: N/A
Power handling:	<ul style="list-style-type: none"> • 1200w
Sensitivity (1):	<ul style="list-style-type: none"> • 98 dB
Directivity:	<ul style="list-style-type: none"> • Omni-directional
Impedance:	<ul style="list-style-type: none"> • 8 Ohm
Construction:	<ul style="list-style-type: none"> • 18mm Birch plywood
Finish:	<ul style="list-style-type: none"> • Water based textured black paint
Connections:	<ul style="list-style-type: none"> • 2 x Neutrik NL4 connectors • 1+/1- Input 2+/2- linked.
Dimensions:	<ul style="list-style-type: none"> • 780mm (W) x 420mm (H) x 600mm (D)
Packaged Dimensions:	<ul style="list-style-type: none"> • 930mm (W) x 545mm (H) x 730mm (D)
Weight:	<ul style="list-style-type: none"> • 42 Kg

Cabinet	Handles	Tophat	M20	Castors	Bracket Pt.	Inserts/Fly Points
SB1	4 off	No	Yes	Optional	N/A	N/A

Note: (1) Sensitivity measured at 1 metre with 2.83V, using band limited pink noise.